

PRODUCT DATA SHEET

CLA-C3X • 811523



BRAND



PRODUCT DETAILS

The C3X is a Self-Priming centrifugal jet pump with excellent suction capacity, even when air is present in the water.

With its compact sizing and a handy carry handle, C3X is portable and therefore suitable for emergency use such as drawing water from tanks or rivers.

Supplied with a plug and play automatic on/off controller which is connected to the pump via a simple, innovative swivel union making fitment and operation easy.

The removable, easy to clean integrated pre-filter protects the pump and and a easily servicable non-return valve is built into the pump body.

APPLICATIONS

- Household water supply
- Gardening
- Drinking water

FEATURES

- Automatic On/Off. 1.5 bar start pressure
- Dry-Run Protection
- Inbuilt Thermal Protection
- Integrated inlet strainer
- Built in Non-Return Valve
- Easy to Use

TECHNICAL DATA

P1 RATED POWER (W)	650
P2 RATED POWER (W)	375
MAX. FLOW [LPM]	55
MAX. FLOW [M3/H]	3.3
MAX. HEAD [M]	35
MOTOR PROTECTION LEVEL	Class F
PROTECTION CLASS	IPX4
LIQUID TEMPERATURE	0°C-35°C
MAX. DIA. OF PARTICLE	2mm
MOTOR	Air cooled

RATED VOLTAGE	220 - 240V
RATED CURRENT	2.3A @230V
POWER CABLE TYPE	HS-05
POWER CABLE LENGTH	1.5m
IMPELLERS	1
INLET	1" BSPF
OUTLET	1" BSPF
PRE - FILTER	Yes - 1mm particles
PACKAGE DIMENSION	640 x 325 x 193mm
GROSS WEIGHT (KG)	9 kg

CURVE

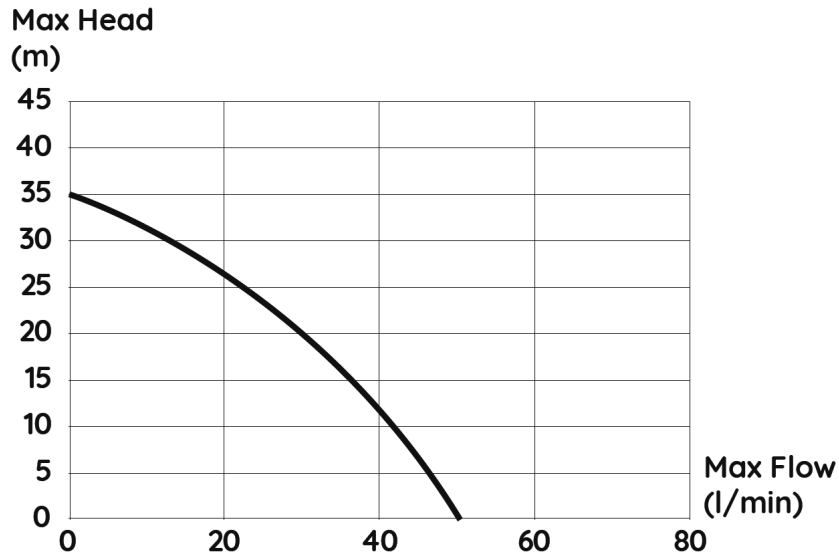

DIMENSIONS

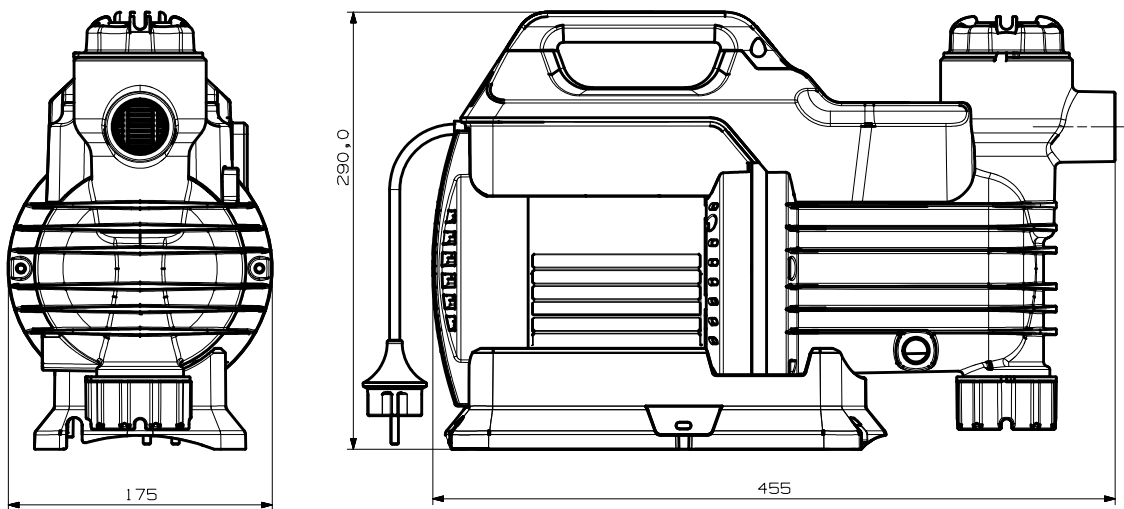

HEIGHT WITH CONTROLLER FITTED (mm)

TBC

WARRANTY / CERTIFICATIONS

